



OWNER'S MANUAL & INSTALLATION GUIDE

Builders' Choice Two-Piece Freestanding Bath

INSTALLER: This booklet must be given to the product owner.

Read all instructions before proceeding. All specifications are $\pm 3/8$ " and are subject to change without notice. Dimensions listed in inches.

Model # _____

Purchase Date _____

Serial # _____

Distributor _____



TABLE OF CONTENTS

PRODUCT WARRANTY REGISTRATION INFORMATION	3
IMPORTANT SAFETY INSTRUCTIONS	4 – 5
INSTALLATION INSTRUCTIONS	
Pre-Installation Instructions	6
Steps	7-8
Plumbing	9-10
ALTERNATE INSTALLATION: DROP-INTO OUTER SHELL	11-12
TUB CARE	
Maintenance	13
Repair	13
WATER QUALITY	
Chemical & Water Quality	14 – 15
AQUATIC LIMITED WARRANTY	17

AQUATIC Product Warranty Registration Information

Thank you for choosing an Aquatic bath. You have chosen one of the finest bath products in the industry. Aquatic supports your purchase with strong commitments to quality and customer satisfaction.

IMPORTANT!

To activate Product Warranty please register with Aquatic.
Your product warranty must be registered and confirmed with Aquatic.

To register, please contact:

Aquatic 800.945.2726 • www.aquaticbath.com/register

Please read and follow all of the instructions contained in this Owner's Manual before installing, operating or maintaining your tub. In addition, you should continually refer to these instructions during the life of your tub. Failure to comply with these instructions may invalidate your warranty. If you have any questions concerning installation, operation, maintenance or any other aspect of your tub, please contact **CUSTOMER SERVICE: 800.945.2726**

NOTE: The installation and service of your Tub should be performed **ONLY** by a licensed contractor.

IMPORTANT!

This product **MUST BE WATER-TESTED** and inspected prior to installation or warranty will be voided. **[See TO INSPECT on page 6.]**
Neither Aquatic nor the distributor will be responsible for removal or reinstallation costs should replacement of the bath be necessary.

PLEASE CHECK ENTIRE UNIT FOR ANY DAMAGE.

If it appears damaged, do not install. Contact your Aquatic Distributor immediately.
Aquatic warranty does not cover damage that occurs in transit.



AQUATIC

The bath people

Customer Service: 800.945.2726 • aquaticbath.com

IMPORTANT SAFETY INSTRUCTIONS

WARNING: When using this unit, basic precautions should always be followed. Failure to follow these instructions could result in personal injury, electric shock, or fire.

READ AND FOLLOW ALL INSTRUCTIONS:

- **DANGER:** To reduce the risk of injury, do not permit children to use this unit unless they are closely supervised at all times.
- Use this unit only for its intended use as described in this manual. Do not use attachments not recommended by the manufacturer.
- Never drop or insert any object into any opening.
- This product is intended for indoor use only. Installing this unit outdoors could cause personal injury and will void your warranty.

WARNING: Prolonged immersions in hot water may induce hyperthermia

HYPERTHERMIA occurs when the internal temperature of the body reaches a level several degrees above the normal body temperature of 98.6°F. The symptoms of hyperthermia include an increase in the internal temperature of the body, dizziness, lethargy, drowsiness, and fainting. The effects of hyperthermia include:

- Failure to perceive heat
- Failure to recognize the need to exit the tub
- Unawareness of impending hazard
- Fetal damage in pregnant women
- Physical inability to exit the tub
- Unconsciousness resulting in the danger of drowning

Your safety and the safety of others are very important.

We have provided many important safety messages in this manual and on your appliance. Always read and obey all safety messages.



This is the safety alert symbol. This symbol alerts you to potential hazards that can kill or hurt you and others.

All safety messages will follow the safety alert symbol and either the word "DANGER" or "WARNING." These words mean:

DANGER

You can be killed or seriously injured if you don't immediately follow instructions.

WARNING

All safety messages will tell you what the potential hazard is, tell you how to reduce the chance of injury, and tell you what can happen if the instructions are not followed.

IMPORTANT SAFETY INSTRUCTIONS

DANGER! TO REDUCE THE RISK OF INJURY:

1. Do not permit children to use this unit unless they are closely supervised by an adult at all times. Supervision is also required when the bath is used by an elderly or handicapped individual.
2. The water in a tub should never exceed 40°C (104°F). Water temperatures between 38°C (100°F) and 40°C (104°F) are considered safe for a healthy adult. Use time should be limited to approximately 30 minutes, followed by a shower to cool down. Longer exposures may result in hyperthermia. The symptoms of this condition are nausea, dizziness and fainting, which can be fatal. Lower water temperatures are recommended for extended use (exceeding 10-15 minutes) and for young children.
3. Since excessive water temperatures have a high potential for causing fetal damage during the early months of pregnancy, pregnant or possibly pregnant women should limit whirlpool water temperatures to 38°C (100°F).
4. The use of drugs or alcoholic beverages before or during tub use may lead to unconsciousness with the possibility of drowning. Never use the tub while under the influence of alcohol, anticoagulants, stimulants, antihistamines, vasoconstrictors, vasodilators, hypnotics, narcotics or tranquilizers.

DANGER: To reduce the risk of injury, enter and exit the bath slowly.

WARNING: Never operate electrically connected devices in or near the bath. Never drop or insert any object into any opening.

To avoid the possibility of personal injury and discoloration of the acrylic surface, the inlet water temperature should not exceed 60°C (140°F). The bath should be drained after each use. Each bather should start their bath with fresh water.

CAUTION: DO NOT USE HARSH ABRASIVES OR SOLVENTS FOR CLEANING THIS UNIT. SEE PAGE 11, TUB CARE.

INSTALLER/OWNER BEARS ALL RESPONSIBILITY TO COMPLY WITH ALL NATIONAL, STATE AND LOCAL CODES WHEN INSTALLING THIS PRODUCT.

SAVE THESE INSTRUCTIONS

INSTALLATION INSTRUCTIONS

READ ALL INSTRUCTIONS CAREFULLY BEFORE INSTALLATION

PRE-INSTALLATION PROCEDURES

PLEASE NOTE: THE MANUFACTURER ACCEPTS A $\pm\frac{3}{8}$ " VARIANCE. THERE ARE VARIATIONS ON EACH TUB AND SPECIFICATIONS ARE SUBJECT TO CHANGE AS WE IMPROVE UPON OUR PRODUCT AS REQUIRED.

THE DIMENSIONS NEEDED FOR SITE PREPARATION AND STRUCTURE BUILDINGS SHOULD BE MEASURED FROM THE TUB; AQUATIC ASSUMES NO RESPONSIBILITY FOR PREPARATORY WORK.

Note: A good knowledge of construction techniques, plumbing and electrical installation according to local and national codes are required for proper installation. We recommend that a qualified licensed contractor perform the installation of all Aquatic products. Our warranty does not cover improper installation related problems.

To Inspect:

1. Immediately upon receiving your Aquatic bath inspect it thoroughly for freight damage. If necessary, contact your dealer/distributor immediately (your dealer/distributor must contact Aquatic, Inc. within 24 hours of receiving unit to file a claim.) Should inspection indicate any damage, do not install the bath.
2. All baths are inspected in our manufacturing facility prior to shipment. Inspectors ensure watertight operation, however, rough handling may cause leaks which may be detected prior to installation.

NOTE: Damage or defect to the finish claimed after the bath is installed is not covered under the warranty.

3. Place the tub in an area where it may be drained after testing.
4. Install the drain (see drain installation sheet) and temporarily plug the drain from the underside.
5. Fill the tub above the overflow and allow water to stand for a few minutes. Carefully inspect for leaks.
6. Inspect the tub completely. Any defect must be reported to Aquatic prior to installation in order to have it covered by warranty. Should inspection indicate any damage or leaks, do not install the bath.
7. Check to ensure that your installation will conform to all applicable codes and secure necessary permits. All plumbing connections should be made by a qualified plumber.

NOTE: Damage or leaks claimed after the bath is installed are not covered under the warranty

CAUTION: You will need at least two people to install this product properly.

WARNING: FAILURE TO FOLLOW THESE INSTRUCTIONS DURING INSTALLATION WILL RESULT IN TERMINATION OF THE WARRANTY: DO NOT STAND IN THE TUB DURING CONSTRUCTION.

INSTALLATION INSTRUCTIONS

TOOLS NEEDED

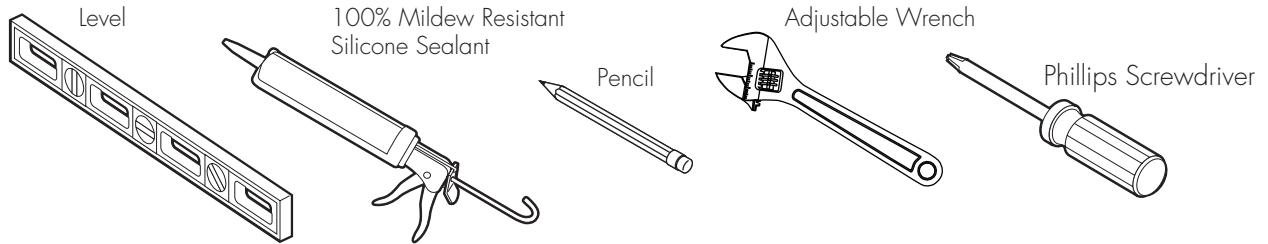

STEPS

1. Remove the bath from its carton and place it on a floor covering to prevent damage to the bath or floor.
2. Position a clean drop cloth or similar material inside the bottom of the bath. Being careful not to scratch the surface.
3. Place tub on a finished, level floor in the desired location.
4. Using an erasable pencil or marker, trace the outline of the base of the tub on the floor. (See Figure 1).

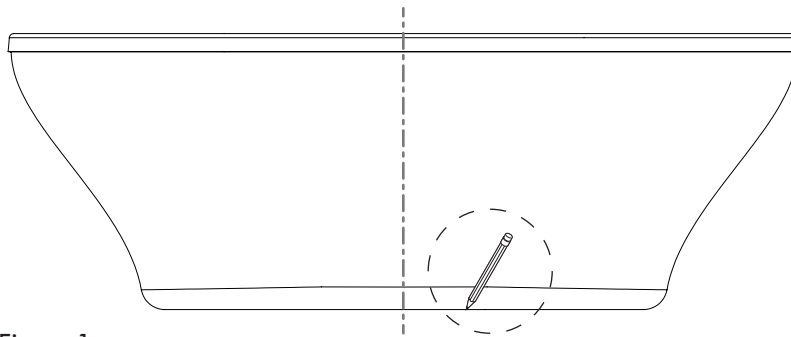

Figure 1

5. Using the adjustable feet on the underside of the tub, ensure that the tub is level with a slight gap between the tub base and the floor. Use a wrench to secure the heights for a level tub. Gap shall not exceed $3/16$ ". (See Figure 2)

NOTE: you will need two persons to manage this task.

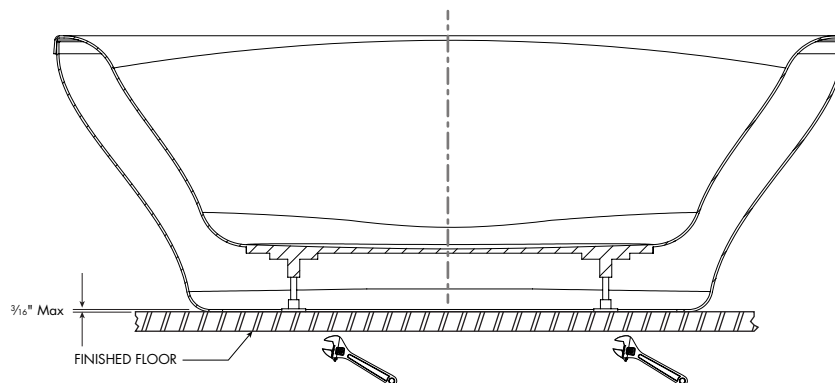

Figure 2

INSTALLATION INSTRUCTIONS

6. Remove the tub. Using the traced outline for reference, confirm that the drain/waste outlet in the floor will align with the tub drain outlet (See Figure 3)

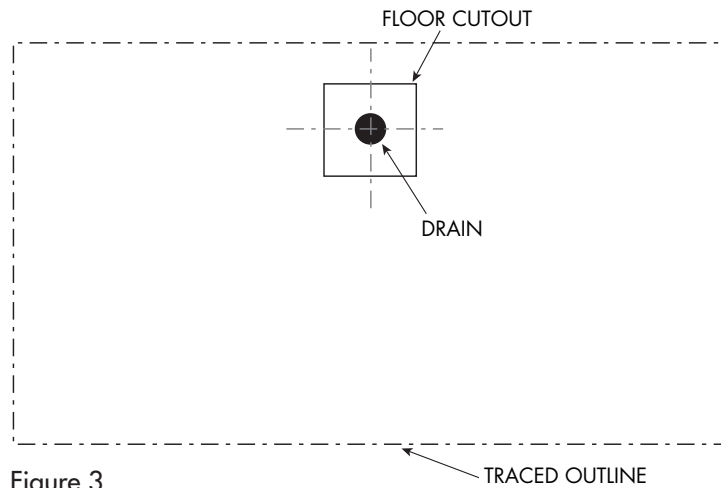

Figure 3

NOTE: Aquatic recommends an access area be provided to facilitate the connection of the drain to the trap through the floor below the tub. Make sure the floor drain and trap are pre-installed in accordance with all local building/plumbing regulations. For drain rough-in dimensions, please refer to the unit's Technical Data Sheet located at www.aquaticbath.com. The unit is shipped with a drain assembly; use the instructions of the drain assembly to attach drain to tub. If instructions are missing, contact Technical Services at: 800.945.2726

7. Carefully set the tub into its final position and connect drain to p-trap/stub-up as directed by the instructions in your drain assembly kit. Fill the bath above the overflow and check for leaks. Apply a bead of silicone around the bottom edge of the tub where it meets the floor. Remove any excess. Allow 24 hours to cure. (See Figure 4)

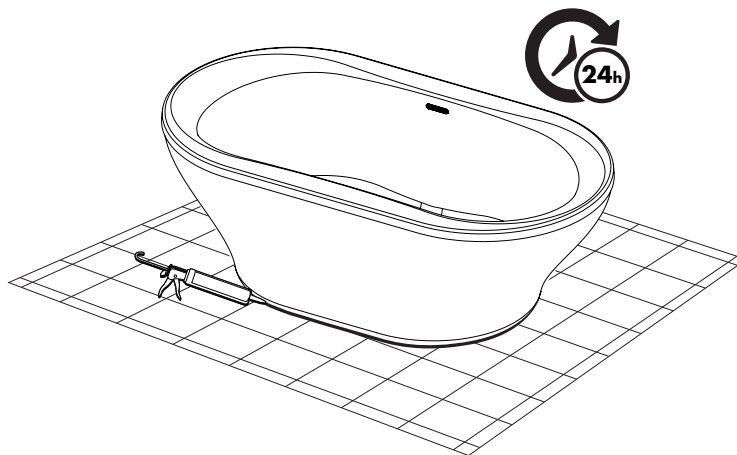

Figure 4

NOTE: Watertight installation of the drain is the installer's responsibility. Drain leakage from installation is not included in the warranty of this product.

INSTALLATION INSTRUCTIONS

PLUMBING

1. When selecting a fill spout location, check to ensure that the spout is long enough to clear the tub rim from its desired location.
2. If fill spout installation is to be on the tub deck, check the back side of the tub for adequate space for connection to water lines before drilling or cutting tub. Detach the screws at the bottom of the tub using a Phillips screwdriver. Then carefully remove the top of the tub and place it on a throw rug or other protective floor covering to prevent damage. (See Figure 5)

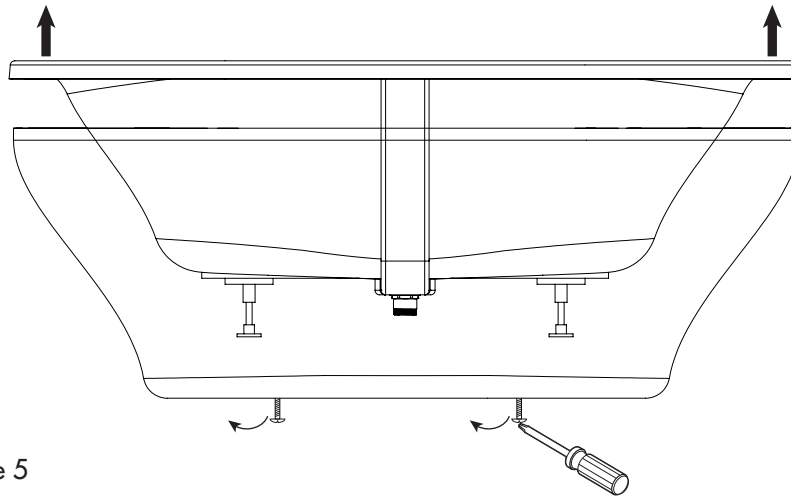

Figure 5

3. Aquatic recommends tub deck fill spouts be mounted above the drain (See Figure 6). Refer to Technical Data Sheets located at: www.aquaticbath.com to ensure there is ample room on the tub deck for the faucet hardware. If hardware is being mounted outside of the recommended area, check the underside of tub rim for obstructions. Install faucets according to the faucet manufacturer's instructions. Verify all pipe connections to ensure no leakage occurs.

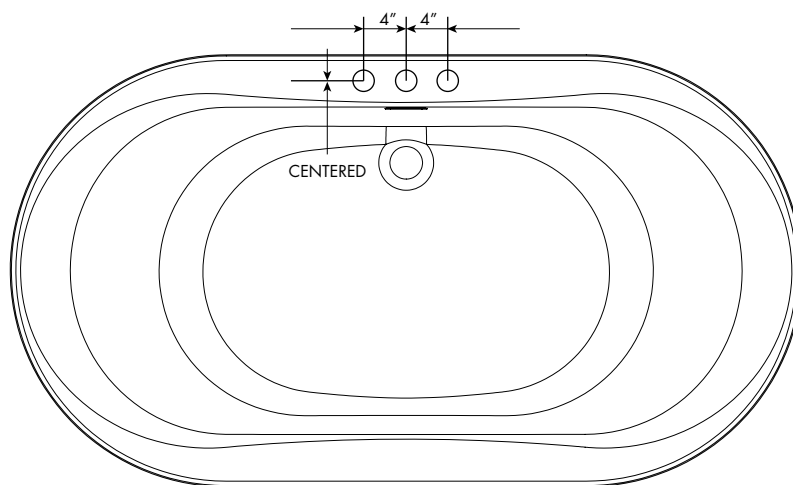

Figure 6

INSTALLATION INSTRUCTIONS

4. Re-assemble the top of the tub with the skirt, and secure the screws at the bottom (see Figure 7). Connect the faucet hose with hot and cold water supply and check for leaks.

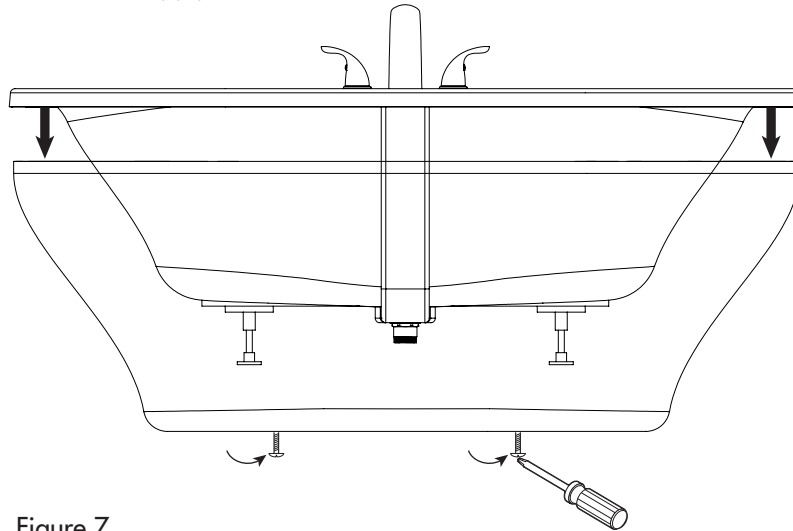

Figure 7

NOTE: Watertight installation of the faucet is the installer's responsibility. Faucet leakage is not included in the warranty of this product.

ALTERNATE INSTALLATION: DROP-INTO OUTER SHELL

1. Remove the bath from its carton.
2. Turn unit upside down on a throw rug or other protective floor covering to prevent damage to the finish of the tub.
3. Detach screws at the bottom of the tub using a Phillips screwdriver. Then carefully separate the outer shell from the inner shell and discard screws. (See Figure 8)

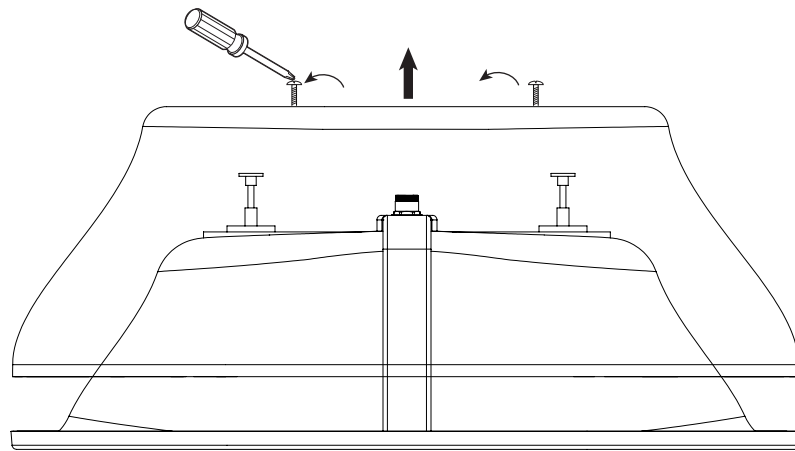

Figure 8

NOTE: Make note of the shell orientations, they should go back together in the same orientation.

4. Set outer shell aside, flip the inside shell right-side-up and set tub in the desired location.
5. Using the adjustable feet on the underside of the tub, ensure the tub is level by using a wrench to adjust the levelling feet to the right height. Tighten the nuts to secure height. (See Figure 9).

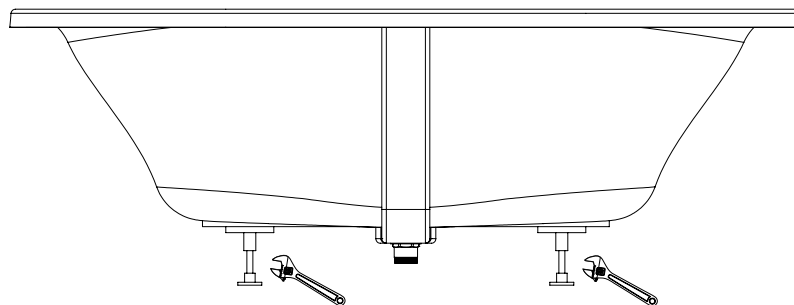

Figure 9

NOTE: You will need two people to manage this task.

6. Confirm valve plumbing height. If additional measurements are needed, refer to Technical/Product Packet sheets located at: www.aquaticbath.com. (See Figure 10)

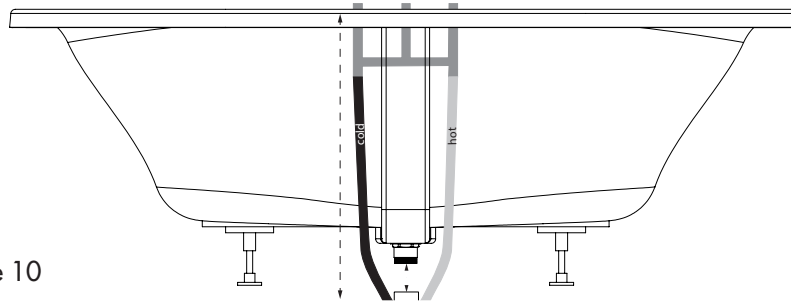

Figure 10

7. Confirm drain clearance underneath the tub and adjust drain pipe height from the building as needed.

NOTE: Anticipate the height difference of glued-in 1 1/2" slip x female pipe thread adapter (not included) (See Figure 10)

8. Drill tub for hot and cold knobs and fill spout placement. If hardware is being mounted outside the recommended area, check the underside of the tub rim for obstructions. (See Figure 6 on Page 9 for recommended mounting locations)
9. Set the outer shell in the final location, with supply lines and valve assembly loosely inside the center of outer shell.
10. Carefully drop the inner shell inside the outer shell while fishing the supply lines and valve assembly into their proper location. (See Figure 11)

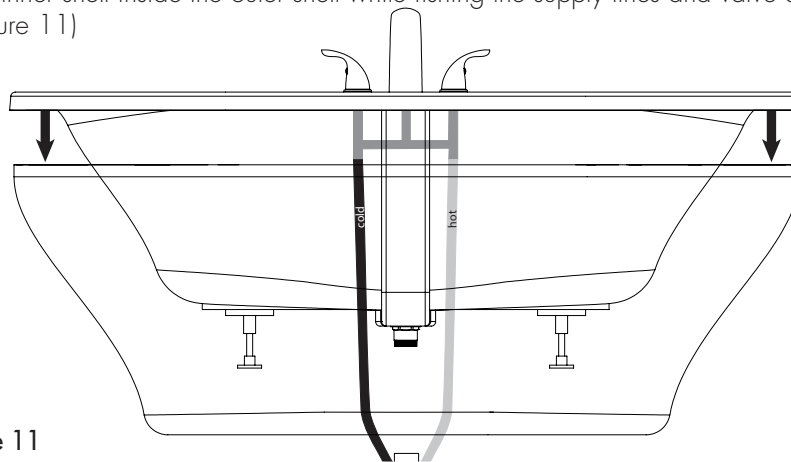

Figure 11

NOTE: YOU WILL NEED TWO PEOPLE TO MANAGE THIS TASK. THE SHELLS SHOULD GO TOGETHER IN THEIR ORIGINAL ORIENTATION FOR THE BEST FIT.

11. Finish attaching valve assembly onto the tub as per the faucet manufacturer's instructions.
12. Make any final tub placement adjustments.
13. Thread in drain from the topside. (see drain installation sheet)
14. Close the drain stopper and fill the bath just above the overflow and check for leaks.
15. Once the unit is leak-free. Apply a bead of silicone around the bottom edge of the tub where it meets the floor. Remove any excess. Allow 24 hours to cure. (See Figure 4 on page 8)

TUB CARE

MAINTENANCE

Surface Cleaning

Use common household, non-abrasive cleaners for most cleaning jobs. For a list of cleaners, visit: <http://aquaticbath.com/service-support/care-maintenance/>. Rinse well and dry with a clean cloth. Never use abrasive cleaners. Do not allow the acrylic surface to come into contact with products such as acetone (nail polish remover), nail polish, dry cleaning solution, lacquer thinners, gasoline, pine oil, etc. Remove dust with a soft, dry cloth. Clean grease, oil, paint, and ink stains with isopropyl (rubbing) alcohol.

Surface Scratch Removal

Minor scratches may be removed by polishing your tub with a non-abrasive car polish, followed by buffing. Deeper scratches can be removed by:

- Sanding with wet 400 grit sandpaper.
- Sanding with wet 600 grit sandpaper.
- Sanding with wet micro-grit sandpaper.
- Buffing out using car polish.

CAUTION: Do not wax/polish the bottom interior of the unit.

REPAIR

The installation and service of your bath should be performed only by a qualified service technician. Remember when contacting your dealer always have your proof of purchase and model number available. This will ensure a quick response on warranty items.

NOTE: ALL WARRANTY REPAIRS MUST BE AUTHORIZED BY AQUATIC BEFORE WORK IS STARTED. FOR SERVICE, ALWAYS CONTACT YOUR DEALER.

CAUTION: Care should be taken to prevent inappropriate chemicals coming in contact with the acrylic surface. Please read and observe all instructions and/or warnings on containers containing substances you contemplate applying to your tub. Any failure to comply may void your warranty.

WATER QUALITY

CHEMICAL & WATER QUALITY

Owners of fill and drain bathtubs need to know basic information concerning water quality, how it affects the performance and enjoyment of the operation of their tubs, and steps that can be taken by the owner to correct related problems. Important issues are the microbiological and chemical quality of the water.

1. Microbiological Quality

Microbes are present in water supplied by individual wells or water systems and even in the air around us. These microbes are usually in amounts below what is noticeable. Microbes from the water or air or from a bather's body may settle on wet surfaces such as bathtub surface or piping system where they can grow in numbers. With regards to bathtubs, brown/black fungi/mold or pigmented (colored) bacteria can be noted.

Fungi/Mold - Fungi and mold are always present. Usually the levels are such that we don't notice them. When moisture and temperature are sufficient, the organisms will grow to levels that we may smell and/or see. The best examples of such growth is the very common black growth on the bottom of shower curtains. The best solution to keep these surfaces free from fungi/mold growth is frequent cleaning.

Pigmented Bacteria - A pinkish substance may appear on bathroom fixtures that is very persistent, appearing in the shower, sink and along the water line of toilet bowls. The residue is less likely a problem associated with water quality than with naturally occurring airborne bacteria. The bacteria may produce a pinkish film, and sometimes a dark gray film, on surfaces that are regularly moist, including toilet bowls, shower heads, sink drains, and tiles. The problem is more common in humid areas of the country. In any particular case, the determination of the exact species of bacteria causing the problem would require lengthy and costly laboratory testing; however, most experts believe the bacteria responsible is *Serratia Marcescens*. These bacteria thrive on moisture, dust and phosphates, and are widely distributed in soil, food and also in animals. The best solution to keep these surfaces free from the bacterial film is continual cleaning. A chlorine containing compound is the best cleaner. Avoid abrasives to limit scratching fixtures, which will make them even more susceptible to bacteria.

2. Chemical Quality

The water supplied by individual wells or water systems always contains chemicals, usually in amounts below those which the consumer would notice. Examples of such chemicals, which are of potential concern for the owners of bathtubs, are calcium and magnesium salts, copper, iron, manganese and sulfates. When these chemicals are present in sufficient amounts, they may cause problems in bathtubs. You should contact your water supply or treatment company and follow their suggestions for treatment.

Calcium and Magnesium Salts - Collectively, the various compounds of calcium and/or magnesium are referred to as salts. Calcium and magnesium salts are often found in ground water supplies and cause "hardness" in water. Hard and soft water are relative terms. Hard water retards the cleaning action of soaps and detergents, causing expense in the form of extra work and cleaning agents. When hard water is heated, it will deposit a hard scale. With regard to whirlpool bathtubs, high calcium and/or magnesium levels may result in the formation of white stains and scale formation on the inside of the tubs, especially noticeable with colored tubs. If this occurs, you need to contact the water supplier to determine the calcium and/or magnesium content and/or corrosion potential of the water and follow their suggestions for treatment. If your water supply is generated from a well, you need to contact a water treatment company to test your water and suggest solutions if a problem is present.

WATER QUALITY

Iron - Iron is found in many natural waters especially from wells. Iron in water can also result from the corrosion of piping in the water supply system, such as cast iron mains or galvanized steel service lines, or galvanized piping in the home water system. High iron levels may result in the formation of brown stains in the vicinity of the faucet outlets of various fixtures in the home. If high iron in the water is present, you can also notice rust colored deposits inside your toilet tank or dishwasher. If this occurs, you need to contact the water supplier to determine the iron content and/or corrosion potential of the water and follow their suggestions for treatment. If your water supply is generated from a well you need to contact the water treatment company to test your water and suggest solutions if a problem is present.

Manganese - Manganese is found in many natural waters especially from wells. High manganese levels may result in the formation of small black particles that can stain laundry, especially noticeable with whites such as sheets or towels. If high manganese in the water is present, you may also notice black stains on white laundry. If this occurs, you need to contact the water supplier to determine the manganese content of the water and follow their suggestions for treatment. If your water supply is generated from a well, you need to contact a water treatment company to test your water and suggest solutions if a problem is present.



**Aquatic Limited Warranty
For Two-Piece Acrylic Freestanding Tubs
Limited Warranty For Original Consumer For Household Usage**

WHAT PRODUCTS ARE COVERED

Structures and surface finishes on Soaking Tubs, and their support equipment, components, attachments, controls and plumbing equipment. Different warranty periods apply to specific components.

Warranty Periods for Specific Components

10 YEAR STRUCTURAL WARRANTY FOR TUB SHELL

Aquatic extends to the original consumer purchaser of the acrylic, fiberglass reinforced shell of tubs a limited warranty that the shell will retain its structural integrity and configuration and be free of water loss due to a defect in the tub shell for a period of 10 years from the date of purchase, but never more than 11 years from the date of manufacture. This limited structural warranty does not apply to attachments to the acrylic, fiberglass reinforced shell, such as: plumbing, fittings, drain, and other apparatuses.

10 YEAR SURFACE WARRANTY FOR FACE OF TUB

The interior and exterior surfaces/faces of a Two-Piece Acrylic Freestanding tub is warranted against fading, blistering, cracking and delamination due to defects in the surface materials for a period of 10 years from the date of purchase, but never more than 11 years from the date of manufacture. This surface warranty extends to defects due to surface material mixing or molding. This surface warranty does not apply to fading, cracking, delamination or blistering due to excessive wear, sun fading or scouring due to cleaning.

2 YEAR EQUIPMENT WARRANTY FOR SUPPORT EQUIPMENT, COMPONENTS, CONTROLS & PLUMBING EQUIPMENT

Related support equipment: Drains on the Two-Piece Acrylic Freestanding Tubs are warranted for 2 years from date of purchase, but no more than 3 years from date of manufacture against defects and workmanship and materials. Limited and reasonable costs may be covered for 2 years from purchase, but never more than 3 years from date of manufacture, for limited labor on the drain.

EXCLUSIVE REMEDY

Aquatic will, at its option and as your sole exclusive remedy, repair or replace (without removal or installation) the affected components of any defective Unit; repair or replace (without removal or installation) the entire defective Unit; or refund the then-current list price of the Tub. In all cases, a reasonable time period must be allowed for warranty repairs to be completed.

WHAT YOU MUST DO

To obtain warranty service under these warranties:

1. You must be the original consumer purchaser of the tub.
2. You must promptly notify Aquatic within the warranty period of any defect and provide Aquatic with any substantiation that we may reasonably request.
Contact Warranty Services: 800.945.2726 • aquaticbath.com
3. The tubs must have been installed and maintained in accordance with good industry practices and the specific Aquatic directions contained in the Owner's Manual.
Contact Technical Services: 800.945.2726 • aquaticbath.com, if the Owner's Manual is missing.

EXCLUSIONS

These warranties do not extend to or do not cover defects caused by:

1. Shipping damage by carriers or installation errors
2. Accidents, acts of God, abuse or misuse
3. Unreasonable use (including any use for non-bathing purposes or failure to provide reasonable and necessary maintenance as specified in Aquatic's Owner's Manual supplied with the Tub).
4. Any alteration, customization, or modification of the Tub or its components

LIMITATIONS

1. Aquatic tubs sold for industrial, commercial or hotel use are warranted for 2 years, but not more than 3 years from the date of manufacture, with a limited warranty that the shell will retain its structural integrity and configuration and be free of water loss due to defect in the tub and the interior surface of the tub is against fading, blistering, cracking and delamination due to defects in the surface materials. This surface warranty does not apply to fading, cracking, delamination or blistering due to excessive wear, sun fading or scouring due to cleaning.
2. In all cases, Aquatic reserves the right to fully satisfy its obligations under the Limited Warranties by refunding the then-current list price of the defective tub (or, if the tub has been discontinued, or the closest comparable current product).
3. Aquatic reserves the right to furnish a substitute or replacement component or product in the event a Tub or any component is discontinued or otherwise unavailable.
4. THESE WARRANTIES ARE NON-TRANSFERRABLE TO ANY OTHER PURCHASER OR PARTY OTHER THAN THE ORIGINAL CONSUMER. NO OTHER AGENT OR PARTY CAN GIVE ANY OTHER WARRANTY OR PROMISE ON BEHALF OF AQUATIC. THIS IS THE SOLE WARRANTY FOR YOUR AQUATIC PRODUCT.
5. Aquatic will not cover any installation or reinstallation costs related to this warranty.
6. For indoor use only. Installing the Tub or any of its components outdoors will void your warranty.

GENERAL

This warranty gives you specific legal rights; you may also have other rights, which vary from state to state. THE DURATION OF ANY IMPLIED WARRANTIES, INCLUDING THE IMPLIED WARRANTIES OF MERCHANTABILITY AND FITNESS FOR A PARTICULAR PURPOSE, ARE LIMITED TO THE DURATION OF THE EXPRESS WARRANTIES HEREIN. AQUATIC EXPRESSLY DISCLAIMS LIABILITY FOR INCIDENTAL AND CONSEQUENTIAL DAMAGES, INCLUDING BUT NOT LIMITED TO: LOSS OF USE, TIME, INCONVENIENCE, OR LOSS OF USE OF RESIDENCE.

SOME STATES DO NOT ALLOW ANY LIMITATION ON HOW LONG AN IMPLIED WARRANTY LASTS, OR THE EXCLUSION OR LIMITATION OF INCIDENTAL OR CONSEQUENTIAL DAMAGES; SO THE ABOVE EXCLUSION MAY NOT APPLY TO YOU.



AQUATIC

The bath people

Customer Service: 800.945.2726 • aquaticbath.com